

TCI H5

H5 Active Line Conditioner

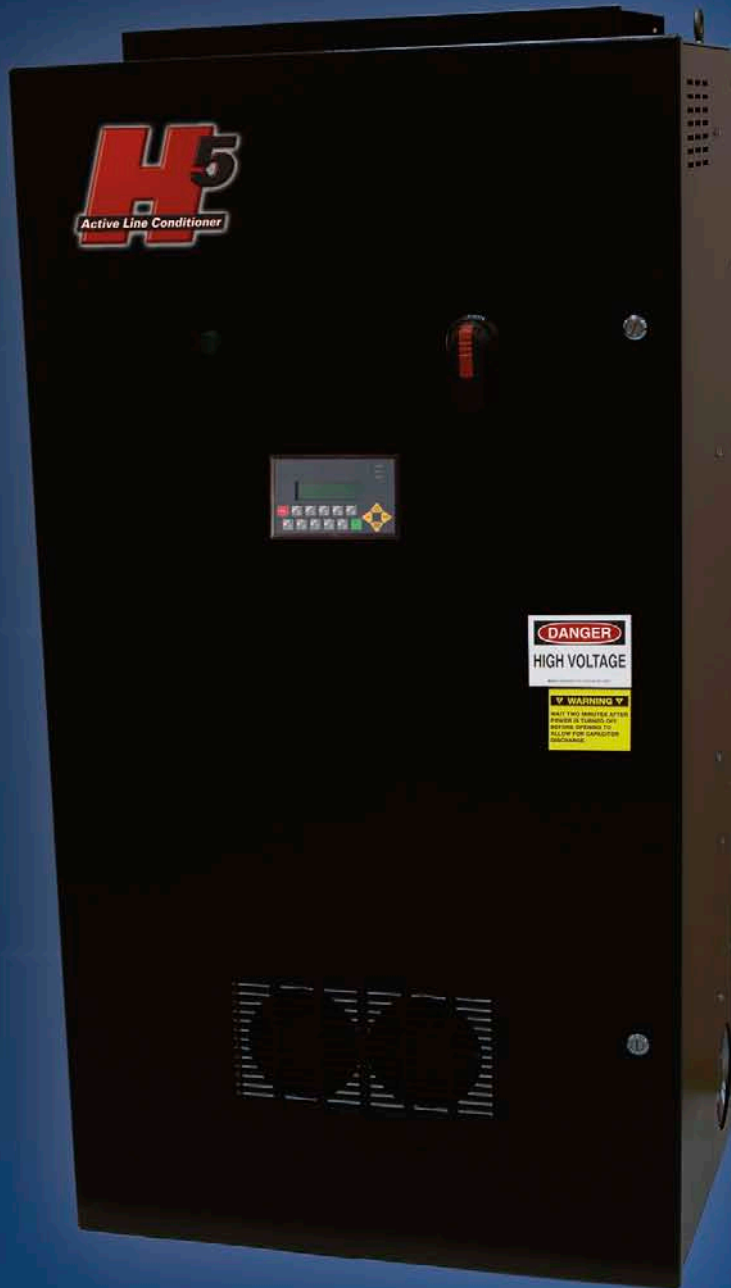

Performance and Protection for Drives



Active Harmonic Mitigation and Power Factor Correction

TCI introduces the H5[®] Active Line Conditioner for overall system efficiency improvement. The H5 actively monitors the load current, reacting to changes in load almost instantaneously, while returning the true power factor to near unity. This dual duty product accomplishes both objectives immediately upon installation without the need for a special commissioning process. The filter's ability to adjust to a dynamic load also means that an expensive harmonic study is not necessary prior to the installation of an H5. The ease of installation plus the superior performance of this filter makes the H5 the ultimate choice in harmonic mitigation solutions.

Typical Problems, Superior Solutions with H5 Filters

Harmonics and Power Quality

Variable frequency drives and other types of non-linear loads take the incoming power from the utility and modify it for more efficient use within a wide range of applications. Since this conversion process is not using the power efficiently as it is supplied from the utility, distortion of both the current waveform and voltage waveform occurs. This distortion is a set of frequencies that combine with the fundamental to create a new waveform. If non-linear loads represent a significant portion of the entire installed load, this distortion begins to cause problems throughout the electrical system. These problems range from transformer and distribution equipment overheating to random breaker tripping. Harmonics may even cause sensitive equipment to fail completely.

Another by-product of this distortion is poor power factor. Unity power factor is achieved when the voltage waveform and the current waveform are truly synchronized and sinusoidal. The combination of reactive power and harmonic distortion contribute to voltage and current waveforms that are not providing true load KW.

The H5 Active Line Conditioner

By actively monitoring the load current, the H5 determines the proper current waveform for injection into the system to maintain an acceptable level of harmonic distortion. A state of the art, high-speed DSP Controller allows for virtual real time correction of the non-linear current demanded by loads such as variable frequency drives. This inherent injection portion of the design of the H5 also allows the filter to control the synchronization of the current and voltage waveforms. This means that the H5 is always attempting to achieve unity power, while never allowing for leading power factor. Another aspect of the H5 design is that in order to maintain optimum system efficiency, the filter will allow the current distortion to rise as the load is decreased. This occurs because the non-linear load is now less of a draw on the entire system and mitigation requirements are no longer the same, all while still driving towards unity power factor.



Versatility

The H5 is one of the most versatile filters available on the market today. The ability of the filter to adjust to varying loads means that it can be applied to different types of loads without the need of an expensive harmonic study. The H5 filter cannot be overloaded by harmonic currents. If there is more corrective current needed than the H5 can accommodate, the unit will go into current limit and the line distortion will rise. If additional harmonic mitigation is required, several H5 units can be paralleled and desired distortion levels can be reached. Typical applications for the H5 filter include:

- Oil and Gas
- Waste Water Treatment
- HVAC Systems
- Down Hole Pumping
- Extruders
- Pulp & Paper
- Uninterruptible Power Supplies (UPS)
- AC Variable Frequency Drives
- Fans

Product Features

- Meets IEEE-519 1992
- TDD Reduction to 5% or better at Full Load
- Power Factor Correction to .98 lagging (programmable)
- Power Factor never goes leading
- Response time is less than 8 ms to step load changes
- Harmonic Currents cannot overload the H5
- Additional filters can be added in parallel to increase correction capability
- Self-Commissioning Installation, no start-up required
- Modular design
- Harmonic Cancellation to the 50th harmonic
- ANSI C62.16 surge protection
- UL / CUL
- NEMA 1 and Open Chassis available



Unfiltered Application

Typical Non-Linear Load Waveform without Filtering

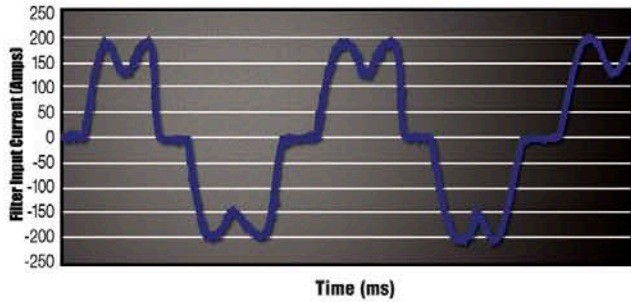

Waveforms

Harmonic distortion occurs as a set of frequencies combine with the fundamental waveform to create a new, distorted waveform. Harmonic distortion can cause damage to sensitive equipment and poor power factor. To address this problem, IEEE-519 1992 set forth distortion limits for power users.

Injection Waveform

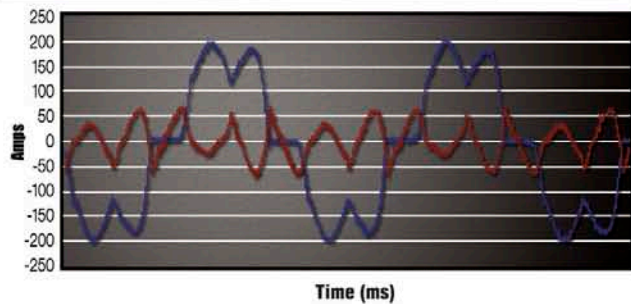

■ Load Current
■ H5 Injection Current

The H5 reduces distortion to meet IEEE-519 limits. The H5 actively monitors the load current and injects equal compensating currents, opposite in phase, to maintain an acceptable level of harmonic distortion. All of this is done in near real time.

Resultant Line Current Waveform

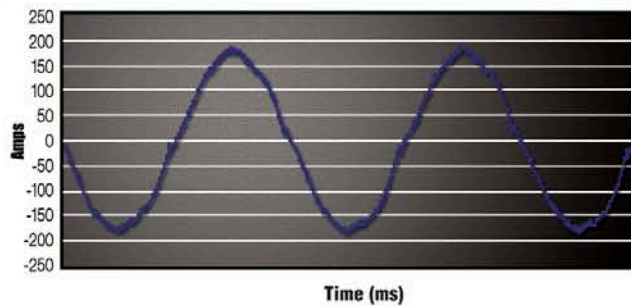

This inherent injection portion of the design of the H5 also allows the filter to control the synchronization of the current and voltage waveforms.

The H5 is always attempting to achieve unity power, while never allowing for leading power factor, resulting in current waveforms that are close to sinusoidal.

H5IM: Interface Module included standard with every unit



The door mounted H5IM Operator Interface Module is an easy to use device that allows for operation and system adjustments for all the H5's setup and operating parameters. The password protected keypad/LED display is also a convenient way to communicate with the filter without the hassle of using an externally connected device.

Functions such as Power Factor, Line Voltage, % of output current and injected harmonics per phase can all be displayed on the easy to read module. A wide variety of status and fault conditions can also be monitored. For example:

- Over Current
- Phase loss (ALC)
- IGBT Failure
- Over Temperature
- Phase unbalance
- Bus Over voltage

H5 Filter Configurations

TCI has designed the H5 filter to be the most versatile filter in the marketplace. Multiple design options allow for the selection of the proper filter for the application.

Bus-Applied

The Bus-Applied Filter combines TCI's Digital Filter Technology with existing system impedance to provide the harmonic and power factor correction solution. This traditional active filter design can be directly connected to the power bus in standard MCC configurations. As with other bus-applied designs, impedance must be installed on the load side of the H5 filter. The small size and superior performance make this design perfect for integration into most applications.

H5 Selection Charts

Active Line Conditioner

Open	Active Line Conditioner					
	Open Part Number	Corrective RMS Current	Watts Loss	Dimensions (Inches)		
				Height x Width x Depth	Wt. (lbs.)	
	ALC50A00H	50	4330	56.00 x 17.00 x 14.36	256	
	ALC50A00S	50	4330	56.00 x 17.00 x 14.36	256	
	ALC90A00H	90	4812	56.00 x 17.00 x 14.36	285	
	ALC90A00S	90	4812	56.00 x 17.00 x 14.36	285	
	ALC170A00H	170	9624	64.13 x 31.80 x 19.09	554	
	ALC170A00S	170	9624	64.13 x 31.80 x 19.09	554	

NEMA 1	Active Line Conditioner					
	NEMA 1 Part Number	Corrective RMS Current	Watts Loss	Dimensions (Inches)		
				Height x Width x Depth	Wt. (lbs.)	
	ALC50A01H	50	4330	56.11 x 17.52 x 16.39	335	
	ALC50A01S	50	4330	56.11 x 17.52 x 16.39	335	
	ALC90A01H	90	4812	56.11 x 17.52 x 16.39	372	
	ALC90A01S	90	4812	56.11 x 17.52 x 16.39	372	
	ALC170A01H	170	9624	64.13 x 32.52 x 21.32	794	
	ALC170A01S	170	9624	64.13 x 32.52 x 21.32	794	

Part Numbering System

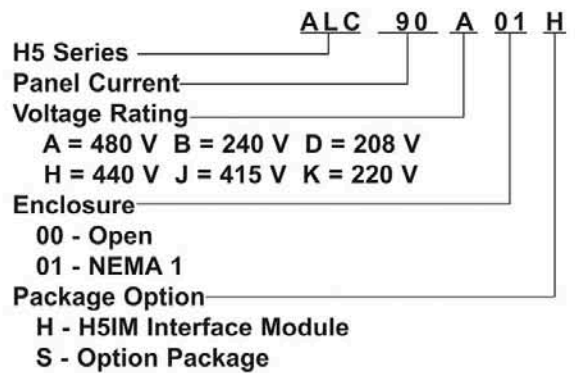

H5 Sizing

When sizing an Active Line Conditioner many factors need to be considered: the size and number of variable frequency drives, desired power factor correction level, future system growth expectations, etc. Also, depending on the use of individual line reactors or DC bus chokes with the VFDs, the amount of corrective current required to meet IEEE-519 and/or specific power factor correction levels can vary greatly. Therefore, please contact your nearest TCI Sales Representative who will help you determine the best solution for today and into the future.

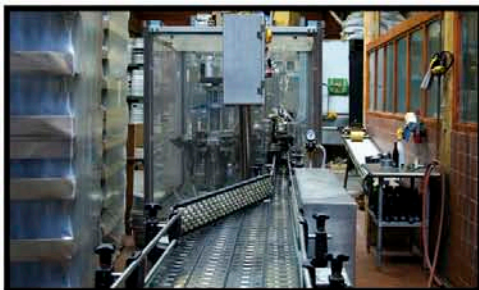

System

Voltage	208/220/240/380/400/415/440/480V
Operating Frequency	3 ph, 50/60 Hz, three wire systems 45 Hz to 70 Hz

Performance

Harmonic Reduction	$\leq 5\%$ TDD (Full Load)
Power Factor Correction	$\leq .98$ Lagging (Programmable), Never Leading
Response Time	< 8 ms to step load changes
Protection	Internal circuit breaker

Agency Approvals

UL/cUL

Enclosure Options

Open Chassis
NEMA 1

Physical Environment

Storage Temperature	-40° to 60° C
Operating Temperature	-20° to 40° C
Maximum Humidity	95%, non-condensing
Elevation	1,000m (3,300 ft) derate $> 1,000$ m

Typical Unit Diagram

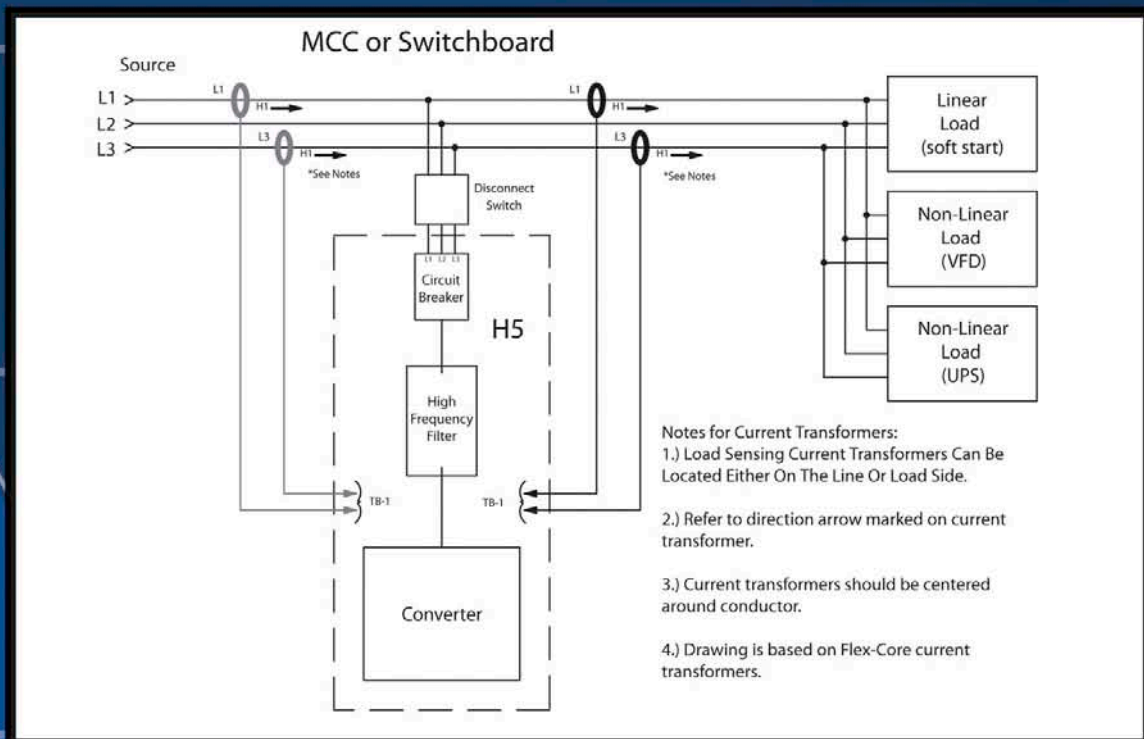

Trans-Coil, Inc. | 7878 North 86th Street, Milwaukee, WI 53224
Tel. 800-824-8282 | Fax. 414-357-4484 | www.transcoil.com

REV.08-01-07
Part Number: 25379