



WEATHERFLO[®] HD

- **Comprehensive solution** for housing VFDs includes integrated cooling via high-performance, shielded impellers
- **Flexible back panel design** facilitates horizontal or vertical panel installation from the rear, allowing easier and safer installation by fewer people
- **Robust construction** supports up to 500 HP VFDs in extreme outdoor applications



WEATHERFLO® HD

APPLICATIONS:

- Irrigation
- Pulp and paper
- Water and wastewater
- Oil and gas
- Mining and boring
- HVAC



Rugged protection and integrated cooling for up to 500 HP VFDs.

Ensure sustained operation of your heavy-duty variable frequency drives (VFDs) in harsh outdoor environments with the Hoffman WEATHERFLO® HD solution from Pentair Technical Products. Forget the hassle of designing a custom solution to house VFDs, adding cooling and hoping the solution will withstand precipitation, debris, animals and more. WEATHERFLO HD is the first comprehensive solution designed specifically to house VFDs in extreme environments—from irrigation pumps to HVAC and general industrial drives.

Featuring shielded impellers to keep dust out of bearings, stainless steel mesh screens on the top and base to keep out animals and debris, and robust aluminum construction, WEATHERFLO HD withstands elements—in the short and long term. Designed for simple installation. Engineered for robust protection and minimal maintenance. Feature rich and tested to the extreme in Hoffman's UL certified test lab. WEATHERFLO HD offers the most complete assembled solution for meeting the demands of heavy-duty VFDs in challenging applications across the globe.

WEATHERFLO Solutions

WEATHERFLO HD is the latest addition to the WEATHERFLO family of enclosures. These enclosures provide a proven solution featuring a forced-air ventilation system for cooling drives or other high-heat producing equipment in outdoor applications. For more information on the complete line of WEATHERFLO products, visit hoffmanonline.com

FEATURES AND BENEFITS:

- **Integrated cooling:** Optional accessory impeller packages provide 840 actual CFM of exhaust airflow per impeller
- **Flexible back panel mounting** options for easier and safer installation
- **Rugged protection** for 100 to 500 HP VFDs
- **UL Type 3R certified:** Tested for reliable protection in extreme conditions
- **Versatile options:** One- or two-door models available; selectable bases, covers and tops
- **Customizable:** Provisions for ganging multiple enclosures together in large applications
- **White paint** for low solar absorption

Two simple back-panel loading options:

Populated back panel is mounted from the rear of the enclosure

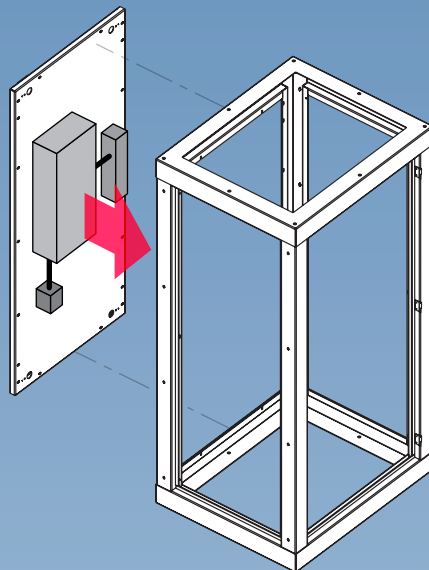

Frame can be lowered onto the populated back panel

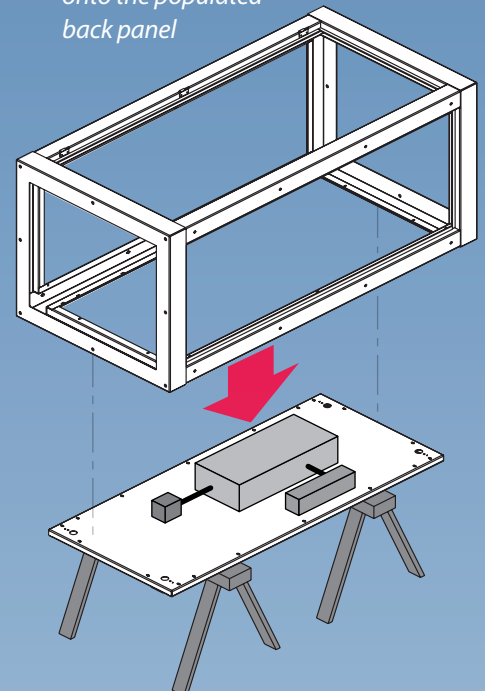



Pagoda or Solid
top styles available

Stainless Steel Mesh
protects against debris

Withstands 100-500 HP
VFD operation

Flexible Back Panel
Mounting

One or Two Door
configurations available

Heavy-Duty aluminum
construction withstands
extreme outdoor environments



Fits **Two Impellers** *per base*
Provide up to **1680 Actual**
CFM *per base*

Solid or Vented
base models available

Flush on Front
to minimize interference

Stainless Steel Mesh
protects against debris



UL tested for durability, airflow and safety.

Industry standards exist to promote safety, encourage design efficiency and define minimum levels of product performance. It's for these reasons that the complete WEATHERFLO HD solution was tested—not just certain components—in an UL approved laboratory. Testing went above and beyond the 3R certification requirements to ensure reliable performance, including durability, optimal airflow and safety features. Trust your VFD investment to a solution that's been tested to the extreme.



Airflow tests measure output and validate actual heat dissipation



UL Type 3R test ensures reliable protection against water ingress

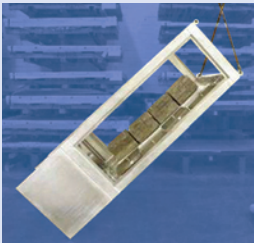

Strength tested up to two-times the safety factor of a typical 500 HP VFD

TECHNICAL INFORMATION

Catalog Number	Model	Description
WFHD3E723630	19916	AL Enclosure 72 x 36 x 30
WFHD3E726830	19915	AL Enclosure 72 x 68 x 30
WFHD3PT3630	20986	AL Pagoda Top
WFHD3ST3630	20996	AL Solid Top
WFHD3PT6830	20991	AL Pagoda Top
WFHD3ST6830	21001	AL Solid Top
WFHD3B3630	21006	AL Base
WFHD3VB3630	21013	AL Vented Base
WFHD3B6830	21007	AL Base
WFHD3VB6830	21012	AL Vented Base
WFHDP7236	21003	Panel
WFHD3RC7236	21904	AL Rear Cover
WFHD3RCH7236	21906	Type 3 HD Rear Cover
WFHD3GP	21015	AL Gland Plate
WFHDJK	21915	WFHD Joining Kit
WFHDFP	21002	Impeller Package

Each component must be ordered separately. See Spec Sheet for additional details and ordering information.



Designed—and tested—for safety you can count on.

- Protected from external debris by stainless steel mesh screens in the top and base to eliminate the possibility of animal, debris and human interaction
- Designed for safer installation
- Tested to the extreme in Hoffman's UL test laboratory; UL Type 3R compliant
- Proven to support up to 500 HP VFDs, strength tested to a two-times safety factor
- 840 actual CFM of exhaust airflow provided by each impeller

CFM INFORMATION

Number of Impellers	CFM	Max Heat Dissipation (in watts) at:			
		10° Delta T	20° Delta T	30° Delta T	40° Delta T
1	840	2,654	5,309	7,963	10,618
2	1,680	5,309	10,618	15,926	21,235
3	2,520	7,963	15,926	23,890	31,853
4	3,360	10,618	21,235	31,853	42,470

Calculated using the following equation: Watts = .316 x CFM x ΔT

About Pentair Technical Products

Pentair Technical Products, a Pentair global business unit, is the leading provider of worldwide product and service solutions for enclosing, protecting and cooling electrical and electronic systems. Its industry-leading brands—Hoffman®, Schroff® and McLean® Cooling Technology—provide a broad variety of standard, modified and engineered solutions to the commercial, communications, energy, general electronics, industrial, infrastructure, medical, and security and defense markets.

Regional Headquarters

North America

Pentair Technical Products
2100 Hoffman Way
Anoka, Minnesota 55303-1745
U.S.A.
Tel: +1-763-421-2240

Brazil

Pentair Technical Products
Pentair Taunus
Eletrometalurgica Ltda
Rua Joao Marcon, 165
18550.000 – Centro Boituva
– SP Brazil
Tel: +55 15 3363 9100

Europe

Pentair Technical Products
Langenalber Straße 96-100
75334 Straubenhardt, Germany
Tel: +49 (0) 7082 794-0

China

Pentair Technical Products
21st Floor of Cloud Nine Plaza
No. 1118 West Yan'an Road
Changning District, Shanghai
P.R. China
Tel: +86 400 820 1133

Singapore

Pentair Technical Products
Hoffman Schroff Pte Ltd.
18 Boon Lay Way
TradeHub 21, #04-110/111
Singapore 609966
Tel: +65 6795 2213

For worldwide locations, see pentairtechnicalproducts.com

