

Instructions for A200, A210, A250 size 6, two- or three-pole non-reversing or reversing motor controllers

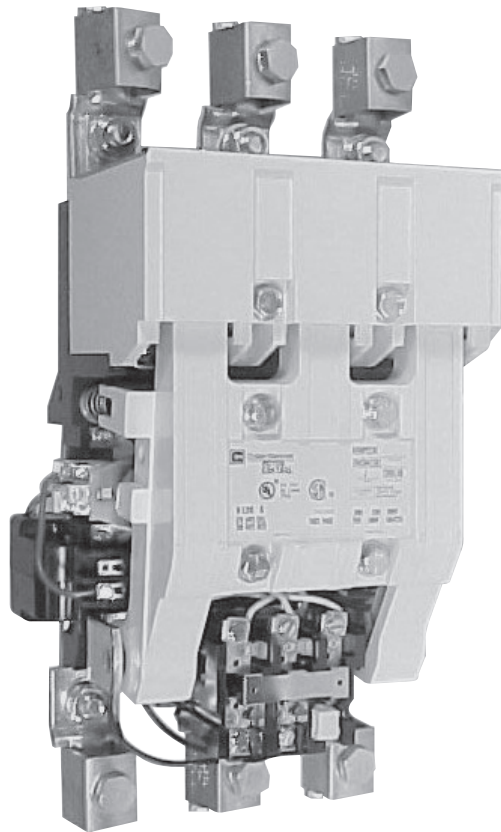

Contents

Description	Page
The controller	1
Installation	2
Type B overload relay	3
Type A overload relay	3
Overload relay heaters	3
Type GCO current transformers	4
Coverage	4
Control relay	4
Auxiliary contacts—type J	6
Line and load terminals	6
Mechanical interlocks	6
Maintenance	6
Magnet suspension	7
Contact overtravel and replacement	7
Contact forces	7
Arc box	7
Kickout springs	7
Operating coil	8
AC/DC coils	8

The controller

An A200, A210, or A250 motor controller, when wired as shown in the appropriate connection diagram, will operate as a full-voltage starter and will give protection against overload. However, it will not protect against short-circuit currents when wired and provided with overload relay (OLR) heaters as listed in heater selection tables or when used with any means of inherent protection activated by motor temperature.

This industrial type-controller is designed to be installed, operated, and maintained by adequately trained workmen. These instructions do not cover all details, variations, or combinations of the equipment, its storage, delivery, installation, checkout, safe operation, or maintenance. Care must be exercised to comply with local, state, and national regulations, as well as safety practices, for this class of equipment.

This motor controller is suitable for use on a circuit capable of delivering not more than the current (rms symmetrical amperes) shown in **Table 1** in circuits rated not more than the voltage shown.

Table 1. Short-circuit ratings

Short-Circuit Protective Device (SCPD)	Maximum size SCPD	Circuit breaker Interrupting rating	Short-circuit withstand rating		Disconnect means—Westinghouse catalog no. prefix
			Current	Voltage	
Class R fuse	600A	—	65,000A 100,000A	600V 480V	MCS (high mag. trip)
Class L fuse	800A	—	65,000A 100,000A	600V 480V	MCS (high mag. trip)
Magnetic only type CB	600A	22,000A 30,000A	18,000A 42,000A	600V 480V	LA
Thermal magnetic circuit breaker	600A	25,000A 30,000A 35,000A	25,000A 30,000A 42,000A	600V 480V 480V	HLB, HLC LA, LB, LC HLB, HLC
Thermal/magnetic type CB + CL	600A	200,000A	100,000A	600V	NB+TRI-PAC

- ① Instantaneous adjustable trip.
- ② Circuit breaker.
- ③ Inverse-time circuit breaker.
- ④ Inverse-time circuit breaker with current-limiting attachment.

Table 2. Controller ratings

NEMA size	Three-phase horsepower at 60 Hz			Amperes	
	200V	230V	460/575V	Open	Enclosed
6	150	200	400	600	540

Two-pole controllers have the same current ratings as three-pole devices but are not suitable for controlling three-phase motors.

Installation

Mount the motor controller on a vertical surface with the line terminals above the load terminals. Once installed, the assembly should be checked to ensure proper operation of the basic contactor mechanism and accessory devices **before power is applied**.

The following list and the **MAINTENANCE** instructions should be used as a guide:

- A. The crossbar and springs must operate freely.
- B. Auxiliary contacts and mechanical interlocks must be properly installed and adjusted.
- C. The proper operating coil must be installed and properly connected.
- D. The crossbar must be in position. The contactor will not operate if the crossbar is rotated forward, out of position.
- E. The arc box must be in place. The contactor must never be operated in a power circuit unless the arc box is securely bolted in place.
- F. The main contacts must have overtravel and spring force and move freely.

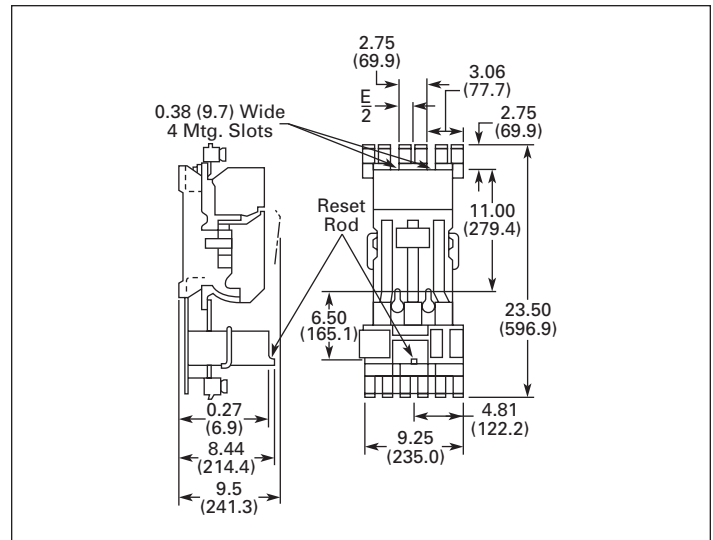
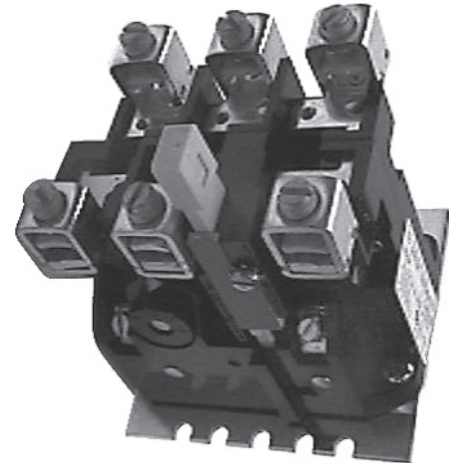

Figure 1. A200 dimension drawing (in inches)

Type B overload relay

A200 motor controllers are usually equipped with a Type B block-type ambient compensated overload relay (with gray reset rod). The controller can also be supplied with a Type B non-ambient compensated relay (with red reset rod). The relay is a bimetal actuated type with a normally closed control circuit contact. An optional isolated normally open control circuit contact is available for field mounting. When the overload relay trips, a yellow dot will appear flush with the molded surface below the reset rod. Resetting the relay returns this indicator to its normal concealed position.



Type B block overload relay

Type A overload relay

An A200 motor controller can be equipped with a Type A non-ambient compensated overload relay (unmarked and with red reset rod) or with a Type A temperature compensated overload relay (marked "ambient compensated" and with gray reset rod). Each relay is a bimetal actuated type with trip indicator, trip adjustment covering $\pm 15\%$ of rating and a normally closed control contact. The relay may be operated in either hand or automatic reset mode.

Reset operation is determined by the position of the plate on the load side of the overload base. Position the reset plate away from the panel to set the "hand" position. Loosen the locking screw, move the reset plate toward the panelboard and retighten the screw to set the "auto" position.

Automatic reset should not be used with two-wire control circuits where automatic starting of the motor may be hazardous.

Overload relay heaters

Overload relay (OLR) heaters are not included with the motor controller and must be ordered separately per the heater selection table and the information listed below. When installing heaters, be sure that connecting surfaces are clean and heaters are attached securely to the relay in the proper location with the screw provided. Install with the serpentine heating element facing away from the reset rod. The trip rating of a heater in a 40°C ambient is 125% of the minimum full load current shown in **Table 3**. When tested at 600% of its trip rating, the relay will trip in 20 seconds or less.

Heaters should be selected on the basis of the actual full load current and service factor as shown on the motor nameplate or in the motor manufacturer's published literature. When the service factor of the motor is 1.15 to 1.25, select heaters from the heater application table. If the service factor of the motor is 1.0, or there is no service factor shown, or a maximum of 115% protection is desired, select one size smaller heater than indicated. When motor and overload relay are in different ambients, and when using non-compensated overload relays, select heaters from the table using adjusted motor currents as follows: decrease rated motor current 1% for each °C motor ambient exceeds controller ambient; increase rated motor current 1% for each °C controller ambient falls below motor ambient.

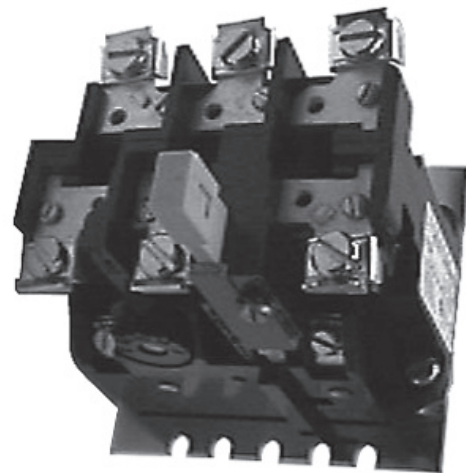

Type A block overload relay

Table 3. Overload relay control circuit contact ratings

Vac	Normally closed		Normally open	
	Make	Break	Make	Break
Type A				
24-120	20A	2A	5A	0.5A
120-600	2400 VA	240 VA	600 VA	60 VA
Type B				
24-120	30A	3A	30A	3A
120-600	3600 VA	360 VA	3600 VA	360 VA

⚠ WARNING

TO PROVIDE CONTINUED PROTECTION AGAINST FIRE AND SHOCK HAZARD, THE COMPLETE OVERLOAD RELAY MUST BE REPLACED IF BURNOUT OF A CURRENT ELEMENT OCCURS. SEE TABLE 4.

Table 4. Replacement overload relay

Overload relay	Catalog number
Type B	
Non-ambient compensated	BN13A
Ambient compensated	BA13A
Type A	
Non-ambient compensated	AN13A
Ambient compensated	AA13A

Table 5. Heater selection A or B overload relay

Motor full load current in amperes for use with three heaters only			
Open starter	Enclosed starter		Heater
Compensated or non-compensated OLR	Compensated OLR	Non-compensated OLR	Catalog (code) number
Size 6 (with 600/5 current transformers)			
236–259	236–259	219–239	FH24
260–283	260–283	240–263	FH25
284–310	284–310	264–287	FH26
311–340	311–340	288–316	FH27
341–374	341–374	317–347	FH28
375–411	375–411	348–381	FH29
412–448	412–448	382–417	FH30
449–489	449–489	418–455	FH31
490–527	490–527	456–494	FH32
528–585	528–540	495–540	FH33
586–600	—	—	FH34

Type GCO current transformers

The Type GCO current transformers were specifically designed to mount on the A200 Size 6 controller and operate the Types A or B thermal overload relays.

The 600/5 ratio Type GCO transformers have a single turn primary winding provided by the controller load connection straps. The secondary wires—one white, the other black—are color coded for polarity identification.

These Type GCO current transformers are not to be used to power additional auxiliary devices and should never be energized with the secondary leads open circuited, because the open circuit overvoltage can damage the transformer.

Coverage

The combination of Type GCO 600/5 ratio current transformers, Type A or B thermal overload relay, Type AR control relay and A201 Size 6 contactor is intended to provide motor overload protection for motors with full load amperes (FLA) from 236 to 600A, 600V.

The overload relay (OLR) must be installed in a vertical position as shown in **Table 6** with the reset rod at the bottom. The Type GCO transformer secondary wires (white and black) are then connected to the OLR terminals with the white wire connected to the upper terminal. Wire pairs (one black, the other white) must be connected to the terminals of the same pole.

Table 6. AR relay data

Contact ratings (A600)					
Volts	Continuous current	Max. current		Max. VA	
		Make	Break	Make	Break
120	10	60	6	7200	720
240	10	30	3	7200	720
480	10	15	1.5	7200	720
600	10	12	1.2	7200	720

Note: Coil Power AC: 96 VA Open, 14 VA Closed, 4.5 Watts Closed.

Control relay

To eliminate the need for a large capacity control transformer or heavy duty pushbuttons, the Size 6 A200 family of controllers includes an interposing control relay with each contactor (symbol CR in **Figure 2** and symbols FX and RX in **Figure 3**). The Type AR relay furnished is a two pole device, each pole rated 10A continuously, up to 600V. The contacts of the AR relay control power to the contactor coil and the AR relay coil, in turn, is operated by the external control scheme. **Figures 2** and **3** show the contactor coils operating at the same voltage as the control relay coils. An optional method of wiring is to take contactor coil power from L1 and L2 via the relay contacts, and operate the remainder of the control circuit at some reduced voltage obtained from a control transformer or a separate source.

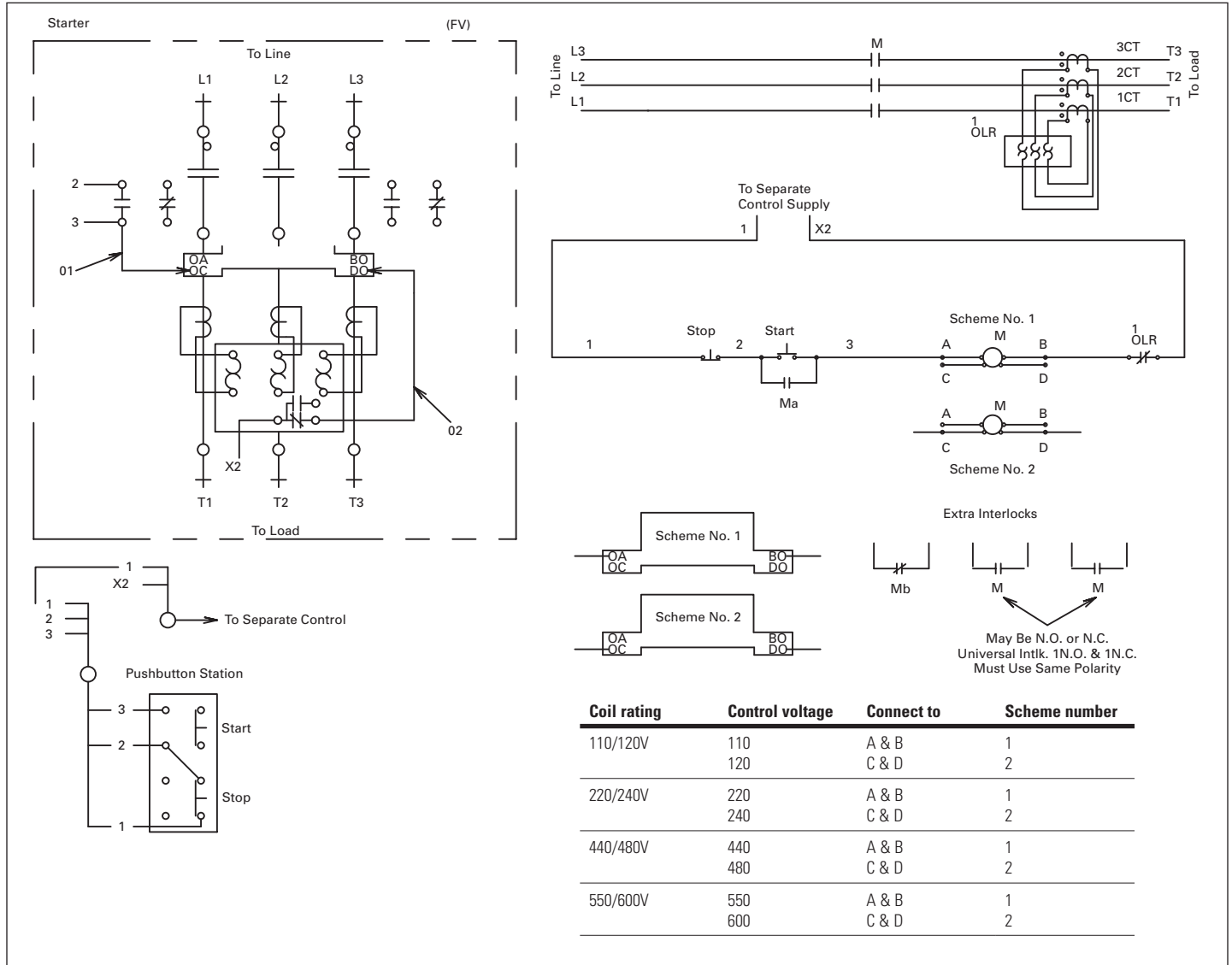

Figure 2. Non-reversing control circuit

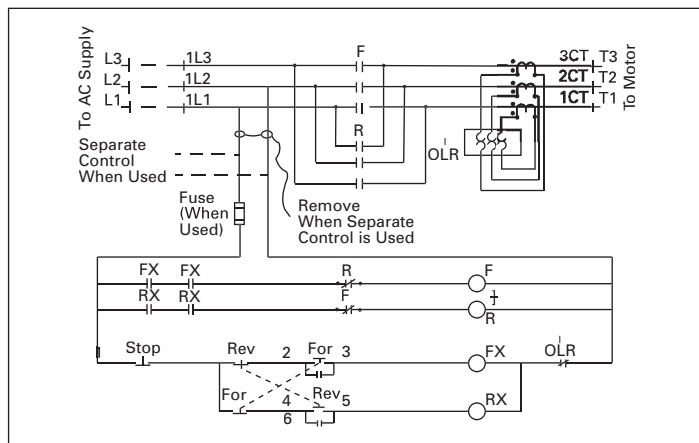

Figure 3. Reversing control circuit



AR control relay

Table 7. AR relay operating coils

Vac	Hertz	Part number
12	60	176C663G06
24	60	176C663G07
48	60	176C663G08
120/110	60/50	176C663G01
208	60	176C663G02
240/220	60/50	176C663G03
480/440	60/50	176C663G04
600/550	60/50	176C663G05

Auxiliary contacts—type J

Each Size 6 controller will accommodate a total of two auxiliary contact units, providing a total of four auxiliary circuits.

The contact unit is retained in a metal bracket by spring clips and operated by a metal operator mounted on the crossbar.

Additional auxiliary contact units are available with various contact arrangements as listed in **Table 8**. The metal bracket, mounting hardware, and operating arm can be ordered as part number 3463D94G01.

The metal mounting bracket is mounted on the contactor base with the hardware provided. The auxiliary contact unit can then be installed.

The metal auxiliary contact operator is then mounted on the crossbar with the hardware provided. Adjust the operating arm so that it strikes the auxiliary contact push rod beyond the beveled edge.

For proper auxiliary contact unit operation, when the contactor is fully closed, the auxiliary contact push rod can be manually depressed 1/16 inch further. If adjustment is necessary, open or close the slot in the end of the operator to obtain this 1/16 inch.

Auxiliary contacts mount by means of a spring clip and retainer. To remove the Type J, loosen the retainer screw several times (counterclockwise) and then slide the auxiliary contact unit out of the bracket cavity.

Table 8. Type J auxiliary contacts

Contact type	Catalog number
2 normally closed	J02
2 normally open	J20
1 normally open and 1 normally closed	J11
1 normally open and 1 normally closed, delayed break	J1C

Type J contact ratings (A600, R300)

Voltage	Continuous	Make	Break
120–600 Vac	10A	7200 VA	720 VA
72–120 Vac	10A	60A	720 VA
28–72 Vac	10A	60A	10A
28–300 Vdc	1A	28 VA	28 VA

Line and load terminals

Both line and load terminals have 1/32-inch diameter holes for 1/2-inch diameter hardware. Dual-wire pressure type lugs, when used, should be assembled on the front of the copper connection straps, using the mounting pattern shown in **Figure 4**.

Table 9. Power circuit terminals

NEMA size	Wire size
6	(2) 2/0 AWG–(2) 500 MCM

Note: Wire with copper conductors only. Use 75°C wire.

Table 10. Mechanical interlocks

Upper controller	Lower controller	Use mech. Intlk. Type
Vertically mounted controllers (A250)		
A201 size 5 or 6	A201 size 6	M47
A201 size 6	A201 size 7	M51
Horizontally mounted controllers (A210)		
A201 size 5 or 6	A201 size 6	M48

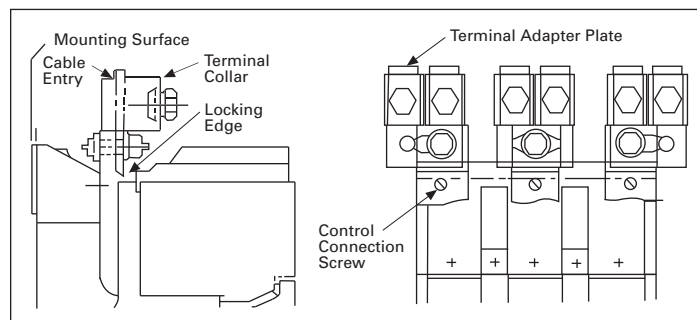

Figure 4. Assembly of pressure type line terminals

Mechanical interlocks

An A200 Size 6 controller, when used in combination with other contactors, may be mechanically interlocked to protect against the closing of one when the other is already closed. Mechanical interlock combinations, for both vertical and horizontal assemblies, are listed in **Table 10**.

Maintenance

This industrial-type control is designed to be installed, operated, and maintained by adequately trained workmen. These instructions do not cover all details, variations, or combinations of the equipment, its storage, delivery, installation, check out, safe operation, or maintenance. Care must be exercised to comply with local, state, and national regulations as well as safety practices for this class of equipment.

Magnet suspension

Both the stationary and moving magnet assemblies are flexibly mounted to ensure proper sealing of the magnet for quiet operation. Both helical compression springs and flat leaf springs are in back of each magnet part. The moving armature has less spring force and restraint than the stiffer stationary magnet assembly. In case these magnets are ever disassembled, particular care must be used to make sure that the flat leaf springs are centered on the laminated magnet assemblies and are not jammed between the magnets and the molded guide projections. After reassembly, be sure to check that both the stationary and moving magnets can be manually depressed or rocked in their mountings. Again, the moving armature assembly can be rocked with much less force and more freedom than the stationary assembly.

Contact overtravel and replacement

The initial contact overtravel, with new contacts, is 5/32 to 13/64 inches and is measured with the power off as shown in **Figures 5** and **6**. Contact replacement is necessary when the overtravel on any pole has been reduced to 3/64 inch. The contacts must be replaced on all poles at the same time. Contact replacement is then achieved by the following procedure with the power off:

1. Remove the arc box and gently lower the crossbar.
2. Disconnect shunts from moving contact.
3. Remove the three contact springs and their protectors. Remove the nameplate.
4. Remove the moving contacts by removing their bearing pins. (A 5/32-inch allen wrench is required for the #10 socket head cap screws.)
5. Remove the stationary contacts. (A 1/4-inch allen wrench is required for the 5/16-inch socket head cap screws.)

To install new contacts, reverse the procedure, making sure all bolts and screws are tight (the stationary contact mounting bolts must be tightened to 150–175 pound inches), the crossbar is raised into its proper position with the moving contacts inside the arc box, and the arc box is securely in place. Check to be sure both kickout and contact springs are properly seated and the nameplate is in place.

The moving contacts should touch the stationary contacts at the same instant within 1/16 inch maximum error on all poles as the contactor is closed. Contact face misalignment of approximately 1/16 inch (measured with the contactor fully closed) will not be detrimental to the operation of the contactor.

Contact forces

With new contacts, the total contact forces per pole should be:

- Initial force 7.5 to 8.5 pounds (**Figure 5**)
- Final force 9 to 10 pounds (**Figure 6**)

After turning off the power, contact forces per pole may be measured by exerting a measured pull until the paper is allowed to move using the method shown in **Figures 5** and **6**.

Arc box

The arc box provides the mechanical stop for the moving contact assembly while maintaining the proper open gap for the main contacts. The molded box also supports the De-ionT type arc quenchers that are contained within the arc box. Two front accessible bolts hold the arc box in place. This arc box requires no maintenance except for a periodic inspection for grid damage or zircon liner burn-through by fault conditions. The contactor must never be operated in a power circuit unless the arc box is securely bolted in place.

Kickout springs

Normally no maintenance is required for these springs other than to make sure they are properly seated on the molded crossbar assembly. In case they are inadvertently removed from the molded base where they are captivated in a hole slightly smaller than the free spring outside diameter, they can be reinstalled readily with needlenose pliers. Hold the front end of the spring, insert the pliers inside the spring, and rotate the offset pin end of the spring in a direction to decrease its outside diameter. Keep the spring restrained until the pin end has been inserted into the molded base.

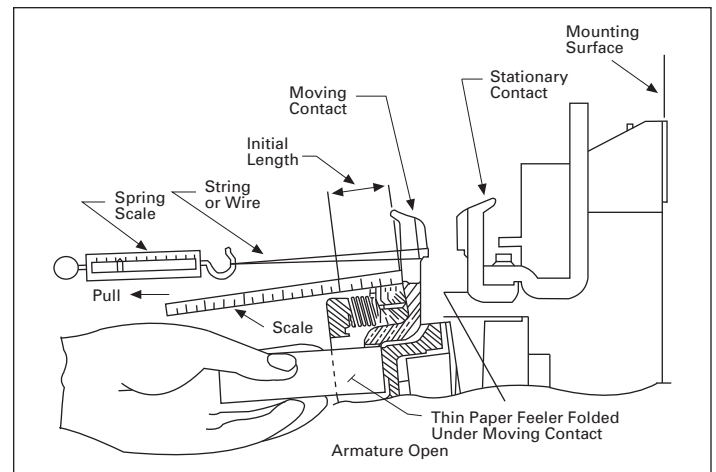

Figure 5. Initial contact force and spring length measurement

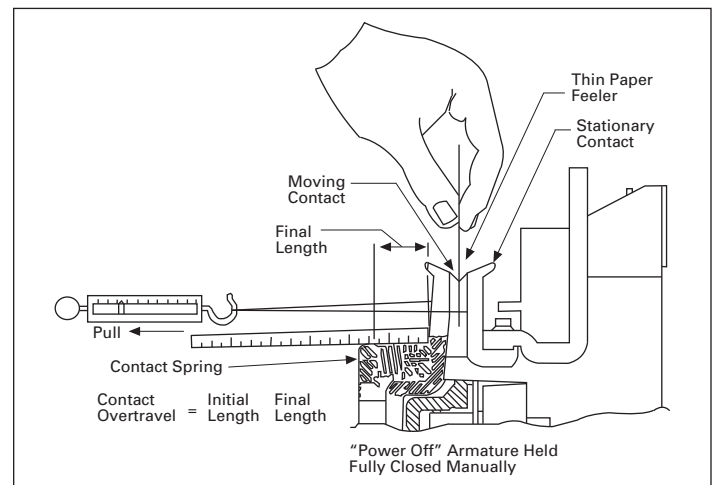

Figure 6. Final contact force and spring length measurement

Operating coil

When installing a new coil, check the identification label for the correct part number, voltage, and frequency.

Table 11 lists the more commonly used coils and shows the connection diagram for each voltage. To replace an operating coil, proceed as follows:

1. Remove all power to the contactor and operating coil.
2. Remove coil leads.
3. Remove the arc box (2 screws).
4. Gently lower the crossbar assembly.
5. Remove the old coil from the magnet by removing the two mounting screws.
6. Place the new coil on the contactor and replace the two mounting screws.
7. Raise the crossbar into its proper position with the moving contacts inside the arc box.
8. Replace the arc box on the contactor and securely tighten both mounting screws. Make sure both kickout springs are properly seated.
9. Reconnect the leads to the new coil. Move crossbar by hand and make sure it moves freely with no mechanical friction.

Table 11. Operating coils for size 6 controllers

Label marking	Control volts 60 Hz	Connect to	Operating coil part number and color of label
	110 120	A-B C-D	2050A12G05 Red
	208–220 240	A-B C-D	2050A12G10 Green
	440 480	A-B C-D	2050A12G15 Yellow
	550 600	A-B C-D	2050A12G17 Gray
	120 240	A-B C-D	2050A12G20* Gray

Note: Supplied connected for 240V with both jumpers wired A to B. For 120V, reconnect the jumpers A to D and B to C as shown on coil label.

Table 12. Coil data (typical values)

Power	Inrush VA	Sealed VA	Sealed watts
AC	2900	220	42

AC/DC coils

AC/DC coil conversion kits are available for use with Size 6 contactors and controllers where low dropout voltage or exceptionally quiet operation is desired. The low dropout voltage characteristic may be required where the voltage applied to the contactor coil is reduced by the effect of motor inrush current. The AC/DC coil accepts AC control voltage and rectifies it to DC. An interposing control relay is required to accommodate the higher coil current involved. To order, select kit from **Table 13**.

Table 13. AC/DC coil conversion kits

Contactor AC/DC Coil Kit		
Voltage	Frequency	Part Number
110–120V	Any	7864A29G01
220–240V	Any	7864A29G02
440–480V	Any	7864A29G03

Table 14. Recommended driving torque

Location	Quantity	Driving torque (lb in)
Arc box screw	2	90–100
Coil terminal screw	2	15–18
Coil mounting screw	2	15–18
Stationary contact screw	3	150–175
Power wire lugs	four-pole	400–440
Lug mounting bolt	two-pole	400–440
Armature mounting screw	4	100–120
Moving contact pivot screw	two-pole	70–80
Shunt screws	two-pole	150–175
Magnet mounting screw	2	15–175

Table 15. Accessories

Fuse block kits—meet requirements of NECT concerning common control fusing

Order catalog number	Quantity	Description
FKR	1	Panel mounted fuse holder for 2 class CC (Bussmann® KTKR) fuses see use when available fault current exceeds 10,000A

Order fuses separately by ampere rating

Controller size	Minimum wire size in control circuit	Suggested fuse size
6	#14 AWG	15A

① Use when available fault current exceeds 10,000A.

② When using a control transformer, select fuse size per the National Electrical Code®.

Table 16. Renewal parts

Item	Fig. 11 refer.	Part number
Contact kit, single-pole	A	2066A10G11
Operating coil	C	See Table 11
Auxiliary contact units	—	See Table 8
Arc box assy., two- or three-pole	B	2066A10G45
Overload relay	—	See Table 4
Control relay	—	See Page 5
Line connector kit, single-pole	D	2066A10G50
Shunt replacement kit, single-pole	E	2066A10G48
Shunt/load connector assy., single-pole	F	2066A10G49

Eaton Corporation
Electrical Group
1000 Cherrington Parkway
Moon Township, PA 15108
United States
877-ETN-CARE (877-386-2273)
Eaton.com

© 2009 Eaton Corporation
All Rights Reserved
Printed in USA
Publication No. IL03303001E / Z8112
February 2009



**PowerChain
Management®**

PowerChain Management is a registered
trademark of Eaton Corporation.

All other trademarks are property of their
respective owners.